

20 LITRE LIQUIDS DRUM

20 Litre Liquids Drum

Drum Brimful Capacity	22.6 Litres
Drum Lidded Capacity	21.9 Litres
Drum Weight	685g +/- 10g
Lid Weight	215g +/- 10g
Handle Weight	25g
Assembled Weight (inc. handle)	925g +/- 10g

Dimensions

Total Assembled Height	427.0mm +/- 2mm
Total Printable Height	306.0mm +/- 2mm
Maximum Diameter	291.0mm +/- 2mm
Base Width	255.0 +/- 2mm

Drum Base Palletisation

Pallet Height	1.37m
Pallet Weight	150kg
Total Drums per Pallet	144*
Total Drums per Stack	10
Stacks per Pallet	16

*Double stacked to 288 per pallet space

Lid Palletisation

Pallet Height	1.15m
Pallet Weight	135kg
Total Lids per Pallet	432

Palletisation

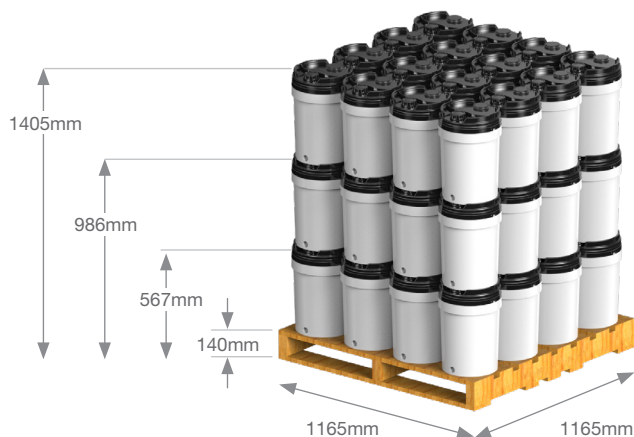

Configuration Options

LID (select one or more)

1. 56mm screw cap
2. Pull up pourer
3. Anti plug pouring device
4. Without openings

DRUM

1. With pierceable 20mm threaded bung opening
2. Fitted 20mm bung



Certification

- ✓ Made from food contact approved materials (FDA)
- ✓ HACCP Codex Alimentarius Alinorm 97/13A
- ✓ ISO 9001: 2015

20 LITRE LIQUIDS DRUM



AYVA's innovative Liquids Drum has been designed to improve the overall user experience - from reducing space requirements before filling, through to ease of pouring and stacking, to lid removal, disposal and recycling. With full wrap In-Mould Labelling (IML) covering the entire printable surface, shelf presentation has never been better!

Features

- Heavy duty foldable carry handle for effortless handling
- Optional anti plug pouring device for seamless pouring
- Removable lid allows for second life use and efficient recycling
- Superior strength & durability with excellent drop test performance
- Full cover In-Mould Labelling (IML) for superior shelf presence
- Optional piercable 20mm threaded opening and bung



- ← Optional Pull Up Pourer
- ← Optional 56mm screw cap
- ← Double lock lid for additional security
- ← Nestable when empty, reducing space requirements by up to 5x
- ← Easy run-off lid prevents build up of water or contaminants and can be easily cleaned
- ← Significantly reduces cost of disposal for the end user



IN-MOULD LABELING VIVID COLOURS WITHOUT LIMITATIONS

NEW
TUB
RANGE

Ø95mm 210ml Ø95mm 365ml Ø95mm 520ml Ø118mm 300ml Ø118mm 480ml Ø118mm 565ml Ø118mm 750ml

Flex Point Lid
Fits all ELITE Pails



1.1L 2.3L 4L 5L 10L Sleek 10L ELITE 12.5L ELITE 15L ELITE 20L ELITE 35L Barrel Cartridges



SYDNEY (HEAD OFFICE)
73C Elizabeth Street,
Wetherill Park, NSW 2164
P +61-2-9725-4080 F +61-2-9757-1030

MELBOURNE
1-3 Endeavour Court,
Dandenong South, VIC 3175

For more products
& information visit
AYVA.COM.AU

20 LITRE LIQUIDS DRUM

Dimensions

Lid



Drum

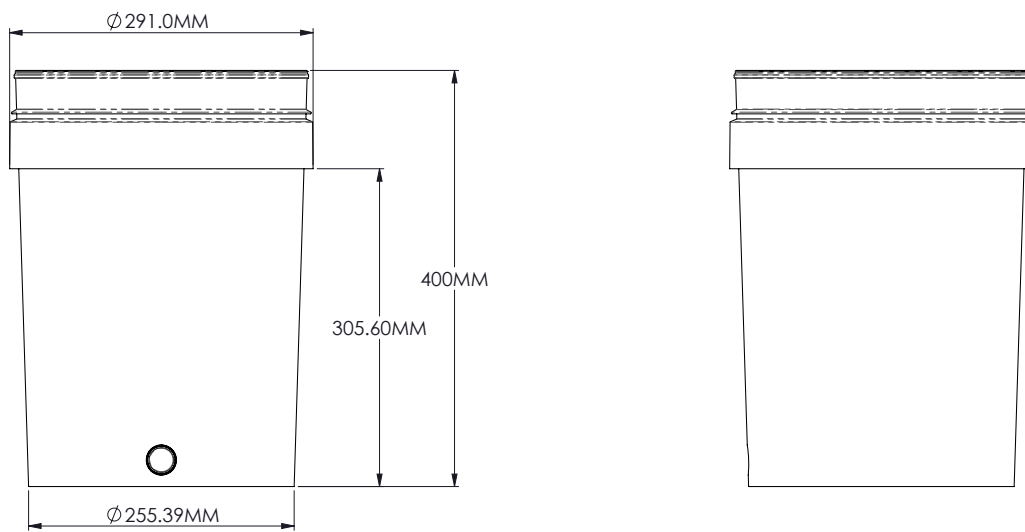

Assembled – Drum with Lid

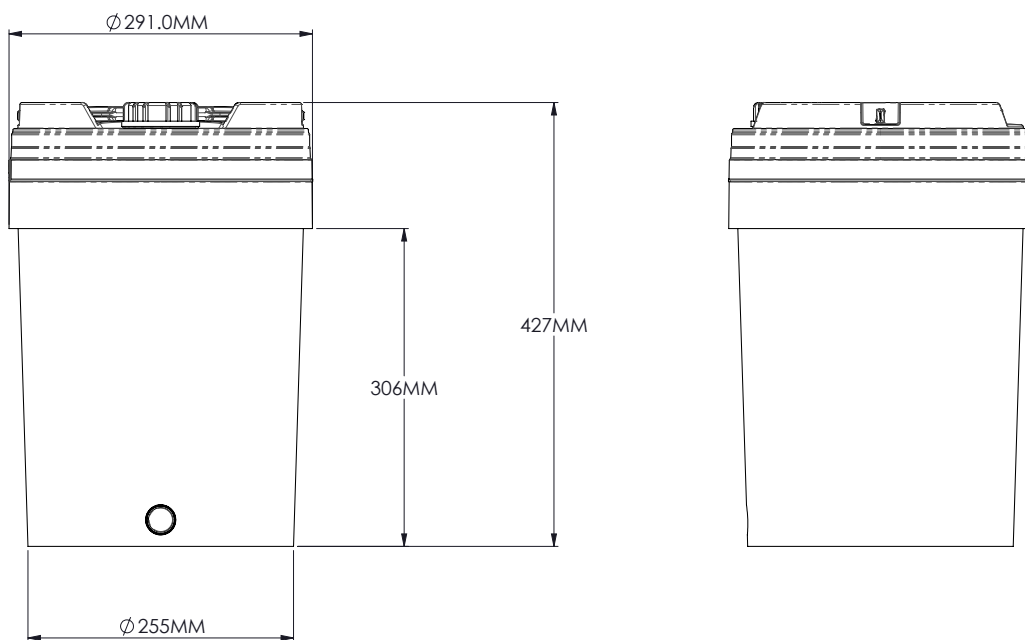

Dimensions

Palletisation

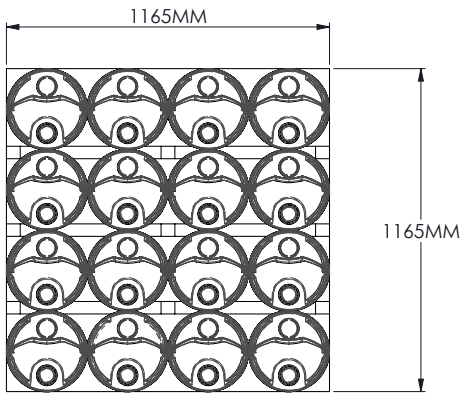

TOP VIEW

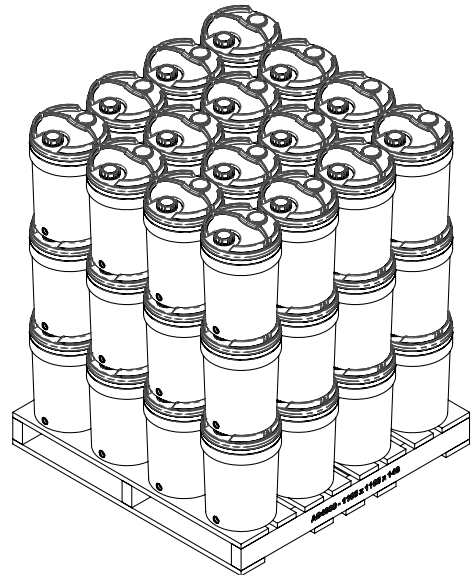

ISOMETRIC VIEW (NOT TO SCALE)

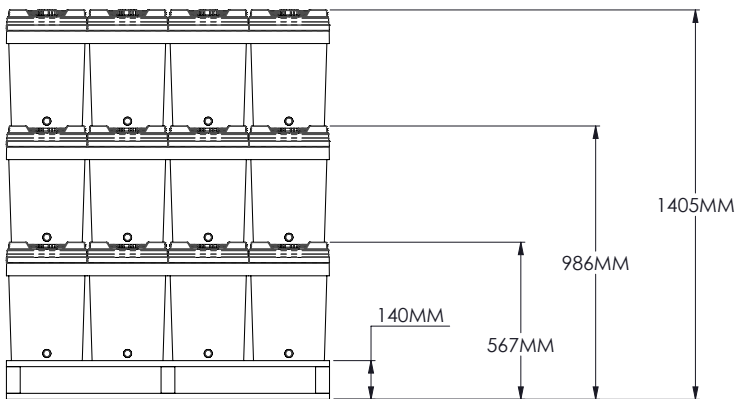

FRONT VIEW